



RAVITAILLEMENT DES
AUTOMOBILES



SYSTÈMES DE GESTION
DU CARBURANT



KITS



POMPES



COMPTEURS



PISTOLETS COMPTEURS

SUZZARABLUE 3 PRO

CARACTÉRISTIQUES

- DESIGN ROBUSTE
- FIABILITÉ NOTAMMENT DANS LES SITUATIONS NON OPTIMALES
- DISTRIBUTION TOUJOURS GARANTIE
- ADBLUE® TOUJOURS PROPRE
- ADAPTÉ À TOUTES LES CONDITIONS ET APPLICATIONS
- FIXATION ERGONOMIQUE POUR IBC
- VASTE POSSIBILITÉ DE CONFIGURATION
- COMPTEUR DE PIUSI (SB325_X METER OR K24)

Le SUZZARABLUE 3 PRO est le top de gamme pour le transfert privatif d'AdBlue® by PIUSI. Adapté à toutes les conditions de travail, pour ravitailler n'importe quel engin industriel ou VUL, la version PRO complète et intégré la version BASIC avec précision du compteur: soit par le biais du K24 pour AdBlue® by PIUSI, soit du compteur intégré dans le pistolet automatique, SB325_X METER by PIUSI.

PERFORMANCES

JUSQU'À

35 L/MIN

DÉBIT

AC/DC

TENSION

6M

LONGUEUR

TUYAU DE DISTRIBUTION

20 MIN

CYCLE DE SERVICE



SUZZARABLUE 3 PRO



PACKAGING

CODE	POIDS		PACKAGING		
	KG	LBS	MM	INCH	PCS/BOÎTE
FO0101510	14,5	32	480X390X310	19,3X15,4X12,2	1
FO0101390	14,5	32	480X390X310	19,3X15,4X12,2	1
FO0101500	14,5	32	480X390X310	19,3X15,4X12,2	1
FO0101440	14,5	32	480X390X310	19,3X15,4X12,2	1
FO0101449	14,5	32	480X390X310	19,3X15,4X12,2	1
FO0101560	14,5	32	480X390X310	19,3X15,4X12,2	1
FO0101430	14,5	32	480X390X310	19,3X15,4X12,2	1
FO010100A	14,5	32	480X390X310	19,3X15,4X12,2	1
FO010101A	14,5	32	480X390X310	19,3X15,4X12,2	1



PISTOLETS



FILTRAGE

SURVEILLANCE
DES LIQUIDES

ENROULEURS



ACCESSOIRES



MERCHANDISE

INDEX



AIR



ANTIGEL



AdBlue®



BIODIESEL



DIESEL



ALIMENTATION



ESSENCE



GRAISSE



KÉROSÈNE



HUILE



EAU



LAVE-GLACE

GRAPHIQUES

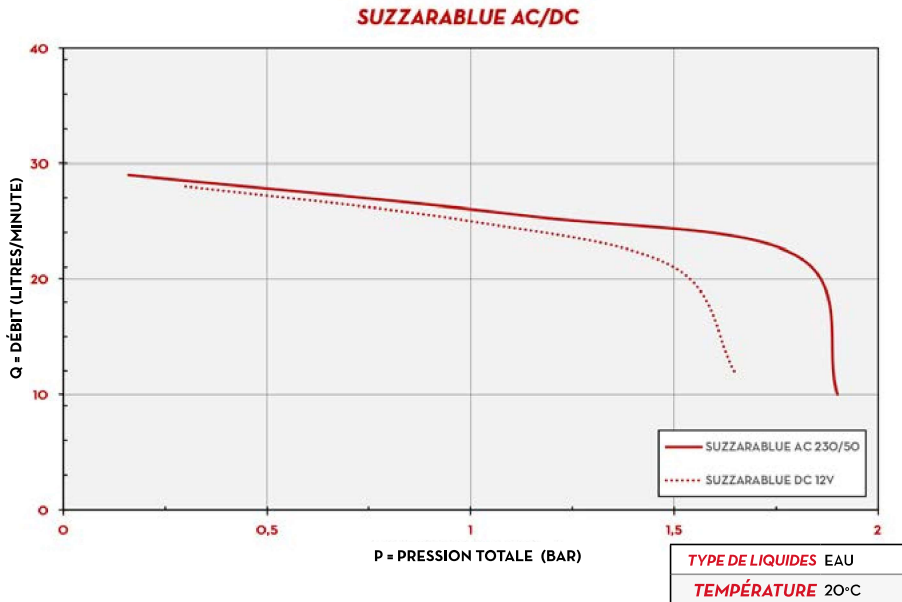

DIMENSIONS

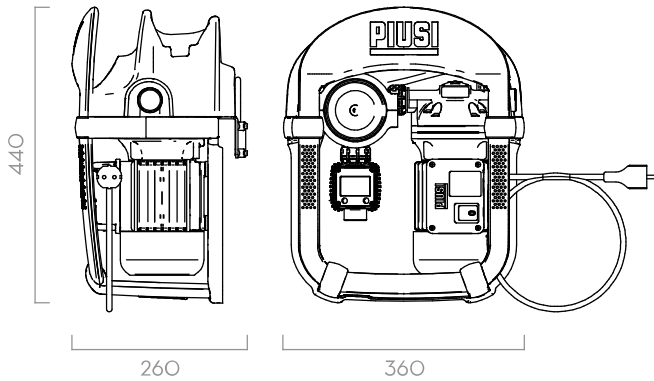

Dimensions exprimées en millimètres

CONTENU DE L'EMBALLAGE

- UNITÉ SUZZARABLUÉ 3
- TUYAU D'ASPIRATION & DISTRIBUTION
- MANUEL/AUTOMATIQUE PISTOLET
- COMPTEUR K24 (SUR DEMANDE)
- CONNECTEUR SEC (*)
- 3D FILTER (SUR DEMANDE)
- MANUEL D'INSTRUCTIONS

DÉTAILS



COMPOSANTS

- POMPES:
SUZZARABLUÉ PUMP AC PAG. 70
SUZZARABLUÉ PUMP DC PAG. 72
- PISTOLET:
SB325_X PAG. 116
SUZZARABLUÉ A60 PAG. 118
SUZZARABLUÉ MANUAL NOZZLE PAG. 120
- FILTRE:
3D FILTER PAG. 126
- COMPTEURS:
K24 PAG. 94
SB325_X METER PAG. 106

DONNÉES TECHNIQUES

CODE	DESCRIPTION	TYPE DE LIQUIDES	DÉBIT		TENSION	COMPTEURS	PISTOLET	FILTRE 3D	CONNECTEUR IBC	TUYAU	
			L/MIN	GPM	POWER					TYPE	TYPE
FO0101510	SUZZ.BLUE3 PRO PURE 12V SB325M	Ad W	35	9,3	12V	SB325_X METER	SB325_X	OUI	SEC	1,5 M Ø20	6 M Ø20
FO0101390	SUZZ.BLUE3 PRO 12V A60	Ad W	35	9,3	12V	K24	A60	NON	SEC	1,5 M Ø20	6 M Ø20
FO0101500	SUZZ.BLUE3 PRO PURE 12V A60	Ad W	35	9,3	12V	K24	A60	OUI	SEC	1,5 M Ø20	6 M Ø20
FO0101440	SUZZ.BLUE3 PRO 230/50 A60	Ad W	35	9,3	230V 50HZ	K24	A60	NON	SEC	1,5 M Ø20	6 M Ø20
FO0101490	SUZZ.BLUE3 PRO PURE 230/50 A60	Ad W	35	9,3	230V 50HZ	K24	A60	OUI	SEC	1,5 M Ø20	6 M Ø20
FO0101560	SUZZ.BLUE3 PRO 230/50 M.NOZ	Ad W	35	9,3	230V 50HZ	K24	MANUAL	NON	SEC	1,5 M Ø20	6 M Ø20
FO0101430	SUZZ.BLUE3 PRO 230/50 SB325	Ad W	35	9,3	230V 50HZ	K24	SB325_X	NON	SEC	1,5 M Ø20	6 M Ø20
FO010100A	SUZZ.BLUE3 PRO PURE 230/50 SB325	Ad W	35	9,3	230V 50HZ	K24	SB325_X	OUI	SEC	1,5 M Ø20	6 M Ø20
FO010101A	SUZZ.BLUE3 PRO PURE 230/50 SB325M	Ad W	35	9,3	230V 50HZ	SB325_X METER	SB325_X	OUI	SEC	1,5 M Ø20	6 M Ø20

*AUTRES CONNECTEURS DISPONIBLES: AF2/EXTERNAL SUCTION

** AUTRES PISTOLETS DISPONIBLES: SB325_X, SUZZARABLUÉ A 60

SUZZARABLUÉ 3 PRO

IBC

57